

# **E/ONE**

---

# **EXTREME**

S E R I E S

---

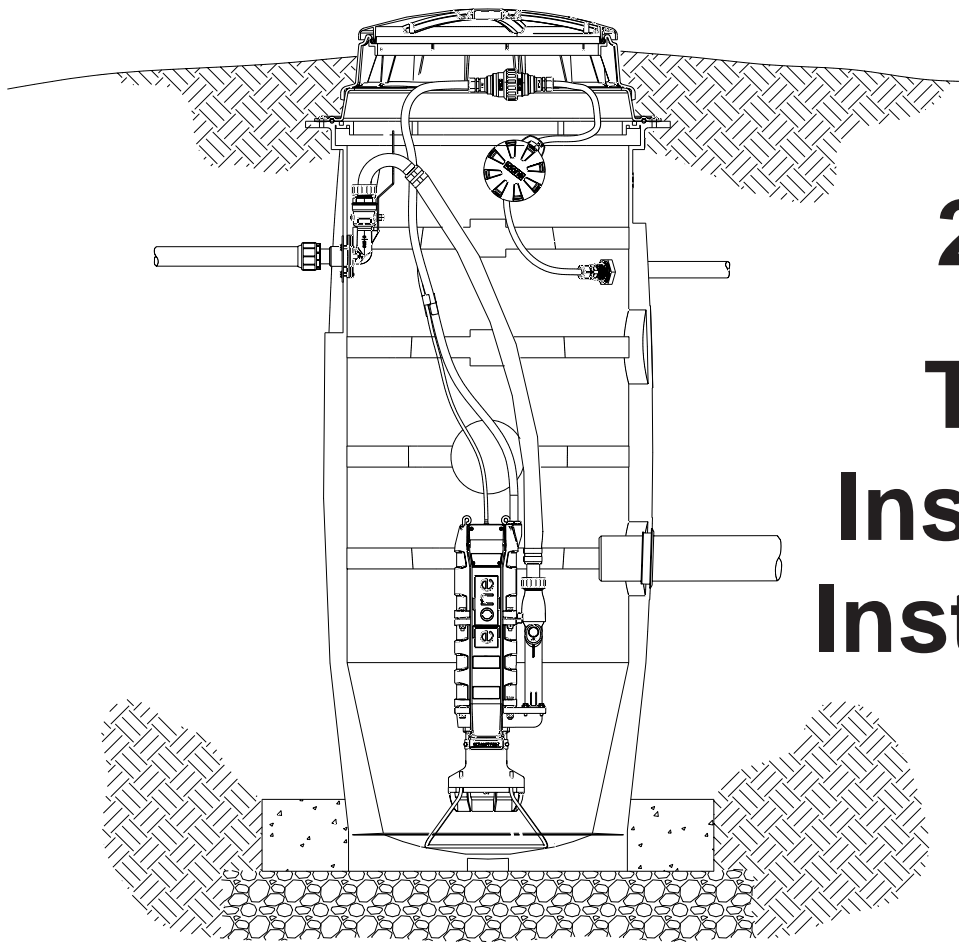

## **2010iP**

# **Typical Installation Instructions**



# 2010iP Installation Instructions

The 2010iP station is a well-engineered system designed to provide low-pressure sewer service to individual residences or buildings. Correct installation and start-up of this equipment will ensure proper operation.

This is a sewage handling pump and must be vented in accordance with national and local plumbing codes. This pump is not to be installed in locations classified as hazardous. All piping and electrical systems must be in compliance with applicable standards, local and national codes and to the satisfaction of relevant authorities.

the tank through the 100 mm DWV uPVC (110.2 mm OD) (standard) inlet pipe where it is ground into fine particles by the grinder pump. The in-line pumping mechanism discharges the macerated sewage to a pressure or gravity main, then to a remote treatment site. The pump is a semi-positive displacement type capable of operating at discharge pressures up to 56 m TDH. Ample tank storage capacity in conjunction with integral level sensing controls provides for economic, on-demand, operation of the grinder pump.

equipment. In addition to the components furnished with each station, the following items will be needed to support installation:

- Electrical supply in accordance with the specification on the pump nameplate.
- Bedding material (Section 2)
- Concrete ballast (Section 5)
- 100 mm DWV uPVC (110.2 mm OD) inlet pipe (from residence or building sewer) (Sections 4 & 7)
- PE100, 40mm OD, PN16, SDR11 polyethylene discharge pipe to force or gravity main (recommended – Section 8)
- Compactable backfill material (Section 11)

## PRODUCT DESCRIPTION

The 2010iP station consists of a grinder pump, tank, pump alarm panel and connecting power (supply) cable. The tank is a polyethylene basin complete with a gasket-sealed lid. Three lid styles are available for the 2010iP station (Figure 4). Sewage enters

## ITEMS REQUIRED FOR INSTALLATION

Prior to beginning installation of the 2010iP station, a thorough review of these installation instructions is recommended. This will likely eliminate problems with inconvenient piping and cable locations or due to the unavailability of materials or

The following tools:

- 127mm (5") dia. hole saw
- Pipe thread sealant (suitable for materials being joined)
- Pipe wrenches
- Electric drill
- Common hand tools

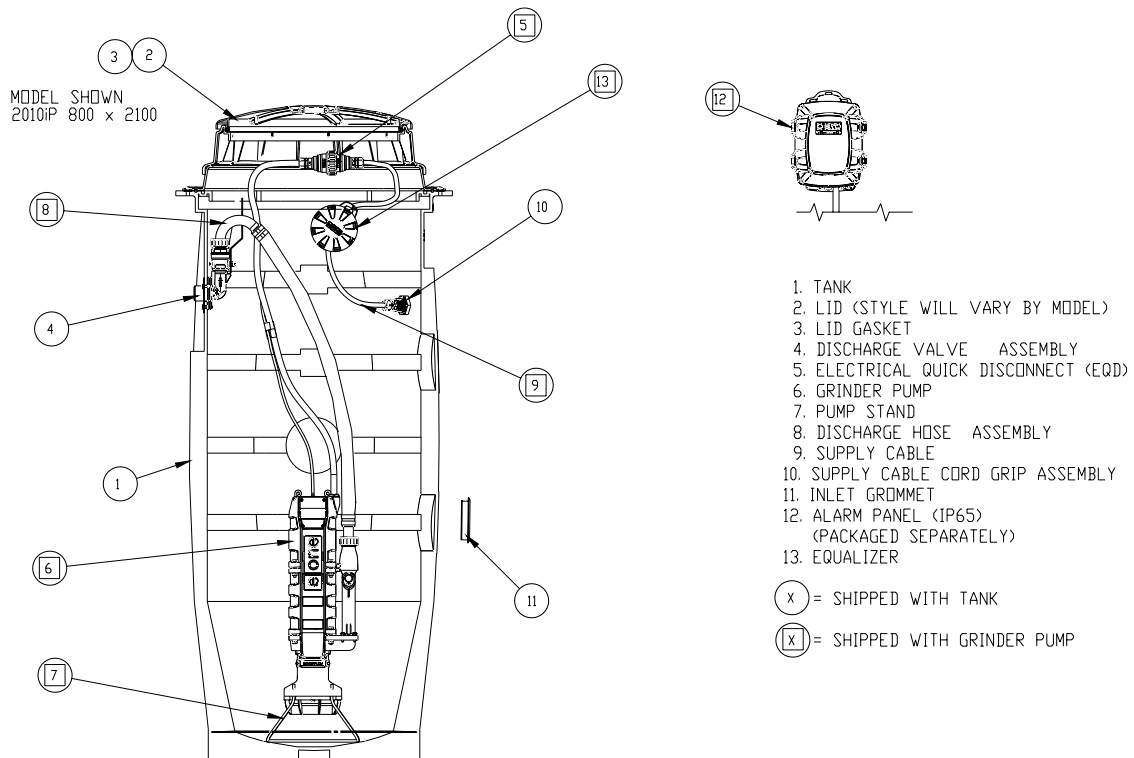

Fig. 1 - Station Components

## INSTALLATION STEPS

The following instructions will provide the necessary information to properly install the 2010iP station.

### 1. Station Unpacking (Figure 1)

The station alarm panel, grinder pump and tank are shipped to the job site separately. Inspect the tank (1) and ensure that it sustained no damage during shipment. Proper handling of the polyethylene tank will ensure reliable performance. Do not drop the tank or roll it on its side. Only a non-marring sling should be used to lift the tank (see Lifting Instructions). Ensure that all lifting equipment is rated for the load being lifted. Remove the tank lid (2) and verify that the supply cable cord grip (10) and the discharge valve (4) are installed in the tank. The inlet grommet (11) was shipped loose with the tank. The balance of the factory-

provided components was delivered with the grinder pump unit. Inspect the shipping cartons for signs of any damage sustained during shipment. Open the pump shipping carton(s) and verify that the grinder pump (6), pump stand (7), discharge hose assembly (8), equalizer (13), and supply cable (9) are enclosed. Open the alarm panel (12) shipping carton(s) and ensure that alarm panel has sustained no shipping damage. If damage is suspected on any of the components, do not proceed with installation. Notify an Environment One representative of any damage discovered or any missing components.

### 2. Site Excavation (Figure 2)

Excavate a hole of sufficient depth and width to accommodate the tank, ballast, underground piping and required backfill material as well as providing adequate working space for

plumbing and electrical connections. The base of the excavated hole should be level and prepared with proper bedding material, such as gravel, in accordance with the site engineer's requirements. The depth of the excavation must be sufficient to accommodate the bedding material and tank burial. The station burial depth depends on the specific 2010iP model being installed. Figure 4 shows the appropriate burial depth by model (cover style) for each. The size, shape and shoring requirements of the excavation will be based on the soil conditions and should be in accordance with the site engineer's recommendation and safety requirements.

### 3. Tank Installation

Improper handling of the tank may result in damage and, ultimately, failure of the station. Care should be taken during lifting and placement to prevent

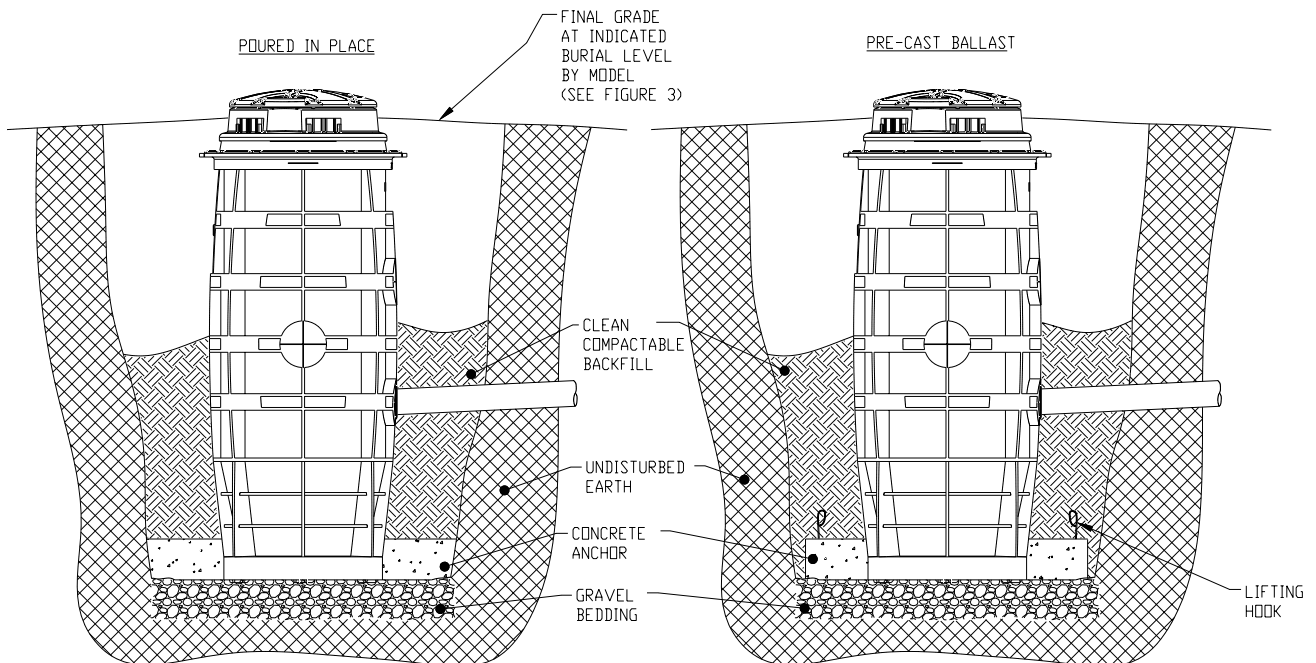

Fig. 2 - Excavation and Ballast

impacting or otherwise damaging the tank. A non-marring sling should be used when lifting the tank (see Lifting Instructions). Ensure that the lifting sling is rated for the load being lifted. Lifting chains or cables should never be placed in direct contact with the tank surfaces. Place the tank on the level bed of fill material in the excavated hole. Orient the installed discharge fitting, as required, to align it with the existing or proposed discharge piping path.

#### 4. Inlet Pipe Location

A 100 mm uPVC inlet grommet was provided with the station for sealing the inlet pipe at the tank wall. Other inlet pipe grommet sizes are also available (Section 7). The location of the tank inlet must be determined to support final positioning of the tank prior to ballast installation. The inlet pipe location corresponds with the actual or projected point where the 100 mm building sewer line

intersects the tank wall. The grade of the inlet pipe and required burial depth (per national and local code requirements) must be accounted for when determining the inlet location. The supply cable path (Figure 6 and Section 10) should be considered when selecting the inlet location. A 127 mm diameter field penetration of the tank wall is required to support installation of the 100 mm (standard) inlet grommet. This penetration must not remove or interfere with any of the structural ribbing on the polyethylene tank. The inlet grommet may be installed in any of the allowable locations shown in Figure 3. The inlet penetration **must** be centered in the location selected to prevent interference with the tank ribbing. Typical inlet installation will be on one of the 200 mm diameter, raised panels on the tank body. The panels have been marked with a series of locating lines to support centering of the drilled penetration. The selected elevation of the inlet

penetration must be in compliance with national and local code requirements. Any inlet installed in the depressed panels between the horizontal and vertical ribbing must be centered within the panel to provide adequate clearance for the 152 mm diameter flange on the standard 100 mm inlet grommet (Figure 3). Do not install inlet in lower, tapered section of the tank. Once the location of the inlet penetration is selected, mark the inlet center location on the tank and position the tank to line up the inlet location with the inlet pipe path.

#### 5. Ballast Installation

A concrete anchor is required to prevent flotation of the polyethylene tank when groundwater is present. The volume of concrete used **must** comply with the site engineer's requirements. Recommended minimum ballast volumes are presented in Chart 1 of the Ballast

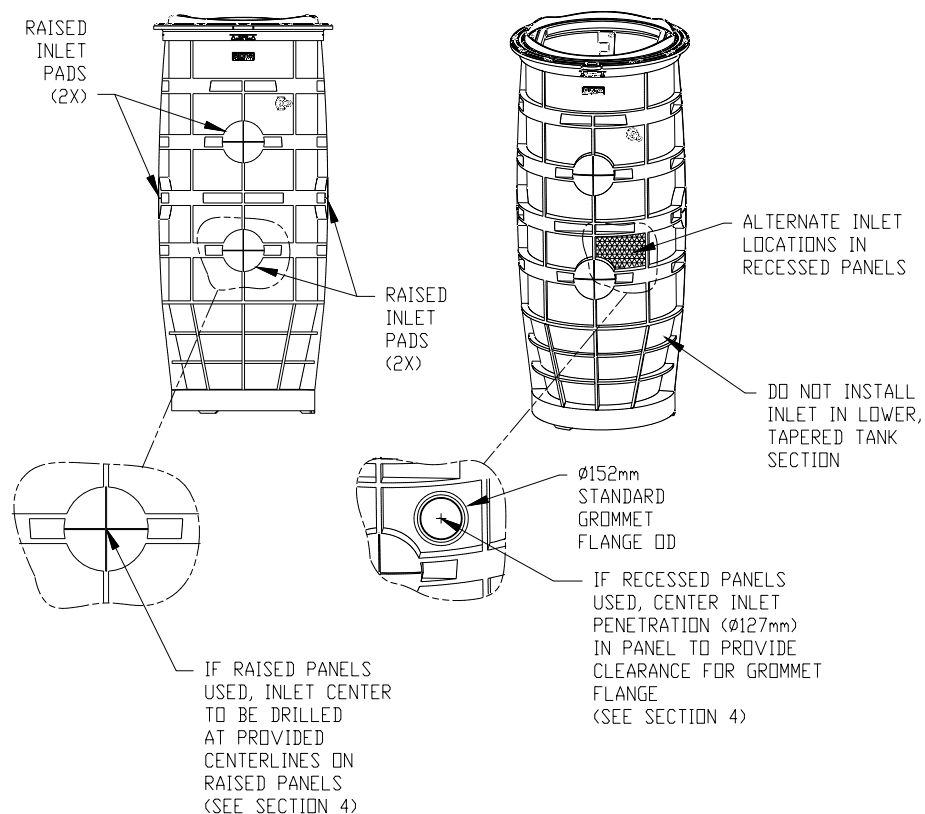

**Fig. 3 - Allowable Inlet Locations**

Calculation page. Ensure that the tank is properly positioned in the excavation to accommodate the marked inlet location (Section 4) before pouring the concrete ballast. Concrete ballast should be cast in place around the tank in the excavation. **Do not pour the concrete ballast above the marked inlet pipe location.** If the ballast must be poured above this level, proceed with installation of the inlet piping (Section 7) before pouring the concrete. The inlet pipe must be sleeved with a 200 mm tube prior to pouring. The tank should be filled with water, to a level above the specified ballast height to prevent shifting during the concrete pour.

Alternatively, precast concrete, around the tank bottom, may be used for ballast (Figure 2). Do not pour ballast above the intended inlet location. If this ballast method is used, lifting hooks must be anchored in the concrete to support subsequent handling of the tank. The lifting hooks must be adequate to support the

combined weight of the tank and concrete ballast, and should be sized and installed in accordance with the site engineer's recommendation. Place the ballasted tank in the excavated hole using the lifting hooks. **Do not lift by any of the tank surfaces if precast ballast is utilized.**

## 6. Venting (Figure 4)

The 2010iP station is a sewage handling pump and requires ventilation for proper and safe operation. The method of station ventilation will vary depending on the specific model ordered. The vent location for each model is shown in Figure 4. Do not bury the station above the appropriate burial line (by model) indicated in Figure 4. Burial above this level will result in blockage of the integral cover vent system provided on most 2010iP models.

If the water level outside of the station is expected to rise above

the surrounding grade (flooding), a cover vent system cannot be used. If flood conditions are expected, an underground (lateral) vent system and solid cover, as shown on the Model 2010iP 800 mm x 1900 mm station, must be used. Refer to the E/One 2000i Lateral Vent Installation Instructions (PA2114P01) for information about underground station venting. **Consult the factory if flood conditions are possible where the station is to be installed.**

## 7. Inlet Installation (Figure 5)

The station is supplied with a standard grommet to accept a 100 mm DWV uPVC (110.2 mm OD) sewer inlet pipe. The grommet is self-sealing and does not require the use of additional sealant or adhesives. Verify that the grommet supplied with the 2010iP station will accommodate the selected inlet piping. Using a 127.0 mm (5") hole saw, drill

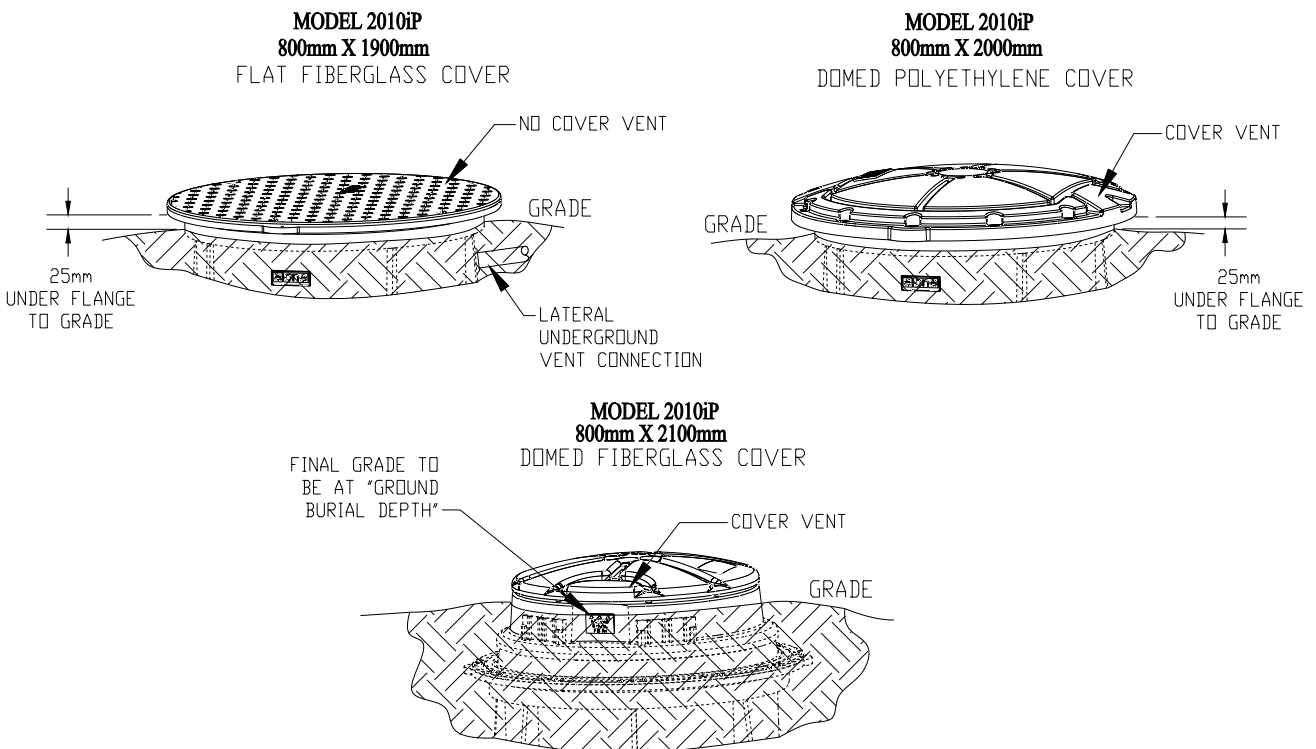

**Fig. 4 - Tank Installation**



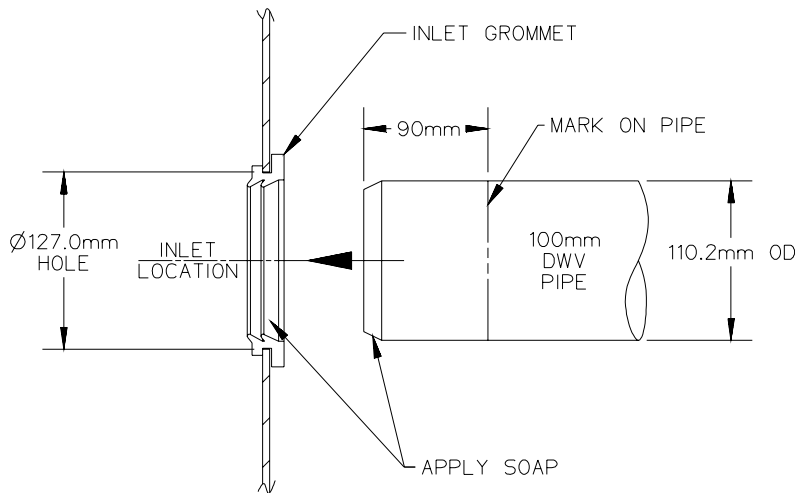

**Fig. 5 - Inlet Installation**

through the polyethylene tank wall at the marked inlet location (Section 4). Remove any burrs or chips from the drilled-hole edges.

*Note: Other grommet sizes are available upon request. Alternate grommet sizes may require a different diameter tank penetration. Consult an E/One representative before drilling the tank inlet if an alternate grommet is required.*

Install the supplied inlet grommet in the drilled hole. Place a mark on the inlet pipe about 90 mm from the end that will enter the tank. A bevel should be ground or filed on the pipe end to aid in installation through the grommet (Figure 5). Clean the grommet and pipe surfaces to remove any debris. Apply a film of pipe soap or dish soap to the outside surface of the inlet pipe end and the inside of the grommet. Insert the beveled pipe end into the grommet and push the inlet pipe into the tank until the 90 mm mark lines up with the grommet's outside edge. Inspect the grommet flange on the outside of the tank. The flange should be flush against the tank wall and completely visible when the pipe and grommet are installed properly.

## 8. Tank Discharge Piping Connection (Figure 6)

Connect the tank discharge piping to the threaded tank fitting. The 1-1/4" BSP female thread on the discharge fitting will accommodate a variety of pipe materials and fittings. Discharge piping must be selected in accordance with local and national plumbing codes. If allowable, the use of PE100, 40 mm OD, PN16, SDR11 polyethylene pipe is recommended. If polyethylene discharge piping is used, compression type fittings that provide a smooth inner passage should be utilized. It is recommended that an isolation valve and a redundant check valve assembly (boundary kit) be installed between the pump discharge valve and the street main on all installations. Never use a ball type valve as a check valve. It is recommended that the valves be installed as close to the public right-of-way (road reserve) as possible. Check local codes for applicable requirements.

*CAUTION: Redundant check valves on station laterals and anti-siphon/check valve assemblies on the grinder pump cores should not be used as system isolation valves during line tests.*

## 9. Alarm Panel Mounting

Before proceeding, verify that the supply voltage is the same as the motor voltage shown on the grinder pump nameplate. Determine the location of the station alarm panel. The alarm panel may be mounted on a pole or directly on an outdoor wall surface. The mounting location selected must be visible from the grinder pump station location and provide general visibility to the occupants of the building. The panel's audible alarm should be easily heard by the occupants of the building. An alarm device is required on every installation, there shall be no exceptions. Mount the alarm panel to a wall or pole, securing it by the mounting flanges with four screws. Any penetrations into the Environment One alarm panel shall be undertaken in such a way as to maintain the integrity of the IP rating (NEMA 4X, IP 65).

## 10. Electrical Connection

### 10a. Supply Panel to E/One Alarm Panel

Wiring of supply panel and Environment One alarm panel shall be carried out per the wiring instructions included with the specific alarm panel provided, in accordance with AS3000, and to the satisfaction of relevant authorities.

### 10b. Grinder Pump to Alarm Panel (Figure 6)

The Environment One 2010iP grinder pump station is provided with a cable for connection between the station and the alarm panel. This cable is referred to as the "supply cable." The supply cable is shipped coiled, inside the grinder pump shipping carton. The supply cable (a six-conductor tray cable) may, under conditions outlined in AS3000, be directly buried. However, Environment One recommends the cable be located within a suitable, rigid, heavy-duty conduit. Minimum depth of the

cable shall be 500 mm. The cable must be provided with adequate mechanical protection and identification per AS3000. The cable and protection must be installed with adequate allowance for ground movement and expansion. All conduit shall enter the alarm panel from the bottom and shall be sealed to maintain the integrity of the IP rating.  
*NOTE: Wiring must be installed in compliance with AS3000.*

**10c. Installing E/One Supply Cable (Figure 7)**

1) Open the lid of the station and locate the supply cable connector on the inside wall of the tank. Loosen the nut on the connector and feed the free end (the end without the E/One EQD housing) of the supply cable through the connector from the inside of the station. Pull the

supply cable out through the connector until it hits the crimped “stop” feature on the cable, approximately 900 mm from the EQD housing.

**\*\*IMPORTANT:** All but 900 mm of the cable must be pulled out of the station, and the cable adjacent to the EQD should be secured in position using the provided hangers to ensure that the pump functions properly (Figure 7). **Do not leave excess cable in the station.**

2) Run the cable underground, in a trench or tunnel, in suitable conduit, per AS3000, to the location of the E/One panel. Use care when installing and burying the supply cable. If the cable is cut or otherwise damaged it may result in a pump malfunction. Connections made at the panel are shown in the wiring diagram accompanying the alarm panel.  
 3) Retighten the supply cable

connector nut. This connection must be tight or ground water will enter the station.

**11. Tank Backfill**

Proper backfill is essential to the long-term reliability of the 2010iP grinder pump station. The choice of backfill material is dependent upon the local soil and groundwater conditions and must be in accordance with the site engineer’s requirements. The recommended method of backfilling is to surround the unit to the burial level (Figure 4) with proper fill. The backfill material shall be to the satisfaction of the local relevant authority. Backfill shall be free of organic and compressible material and shall be free of voids and cavities. Compaction moisture content shall generally be 1% dry and 2% wet of the optimum content.

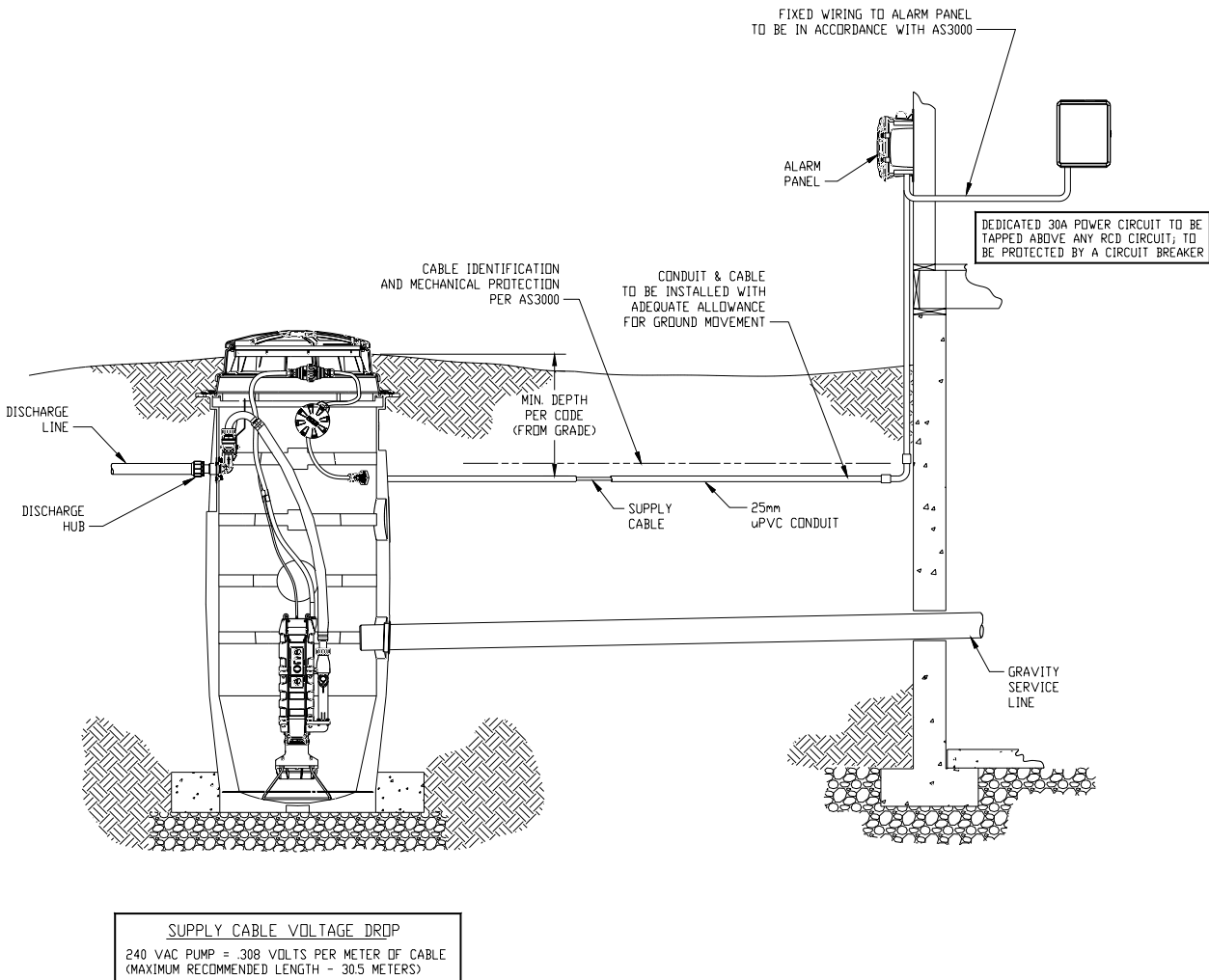

**Fig. 6 - Typical Station Installation**



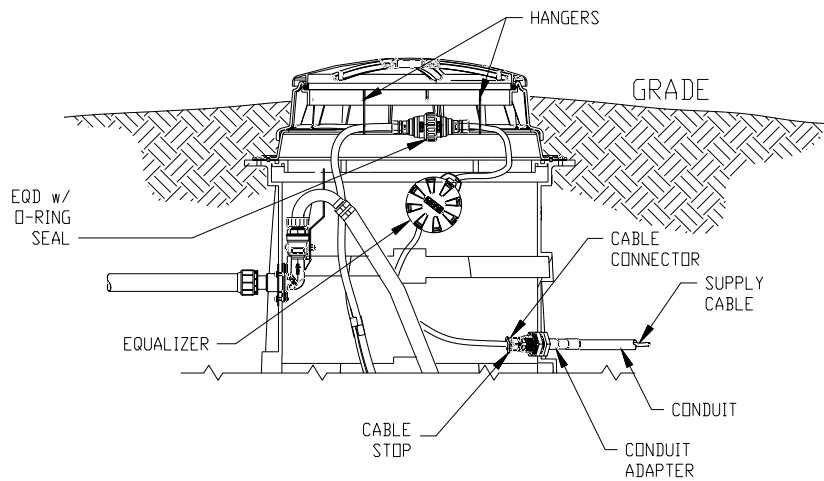

**Fig. 7 - Electrical Cables**

Backfill shall be compacted to the minimum standard dry density ratios, AS1289, 95%. Clays and silts (12% or more passing through #200 (.075 mm) sieve) are **not** suitable backfill for this or any underground structure such as inlet or discharge lines. If you are unsure of the consistency of the native soil, it is recommended that a geotechnical evaluation of the material be obtained before specifying backfill. Another option is the use of a flowable fill (i.e., low slump concrete). This is particularly attractive when installing grinder pump stations in augured holes where tight clearances make it difficult to ensure proper backfilling and compaction with dry materials. Flowable fills should not be dropped with more than 1-1/4 meters between the discharge nozzle and the bottom of the hole because this can cause separation of the constituent materials.

**12. Grinder Pump Stand Assembly (Figure 8)**

Temporarily rest the grinder pump on its side. Using a block of wood or similar object, prop up the lower pump end to allow installation of the pump stand. Align the two legs of each pump stand half with two of the holes in the pump lower end. Push the stand legs into the pump lower end until the bend in each stand

leg bottoms against the pump-housing surface. Turn the pump upright on the installed stand. Install one stand retaining ring on each of the four leg ends protruding through the pump lower end. The retaining rings are a pressure fit and are easily tapped in place using a 8 mm socket or nut driver and mallet. The retaining rings should only be driven onto each leg approximately 6 mm. Do not attempt to bottom the rings against the angled pump surface as this may distort the ring and lessen its holding power.

**13. Pump Installation (Figure 9)**

**The grinder pump should only be installed in the station upon connection and**

**commissioning of the discharge piping, connection of the inlet piping to the building sewer, and upon availability of pump station power from the provided alarm panel to support start-up testing (see Section 14).**

Prior to installing the grinder pump in the tank, flush the inlet pipe with water to force any miscellaneous debris in the sewer line into the tank. Heavy debris, sand, clay, construction materials, etc. should be removed from the tank before installing the grinder pump. The grinder pump was supplied with all of the necessary plumbing components to connect the pump discharge to the tank discharge valve.

1. Ensure that one slip nut and one split ring are properly located behind the raised bead on each end of the discharge hose.
2. Place one back-up ring and one O-ring on each end of the discharge hose assembly between the raised bead and the edge of the hose assembly. *Note that the molded groove in the back-up ring is designed to be placed adjacent to the rubber O-ring.*
3. Slide the straight, stainless steel end of the discharge hose assembly into the top of the check valve assembly on the grinder pump until the raised bead contacts the check valve housing. Both the

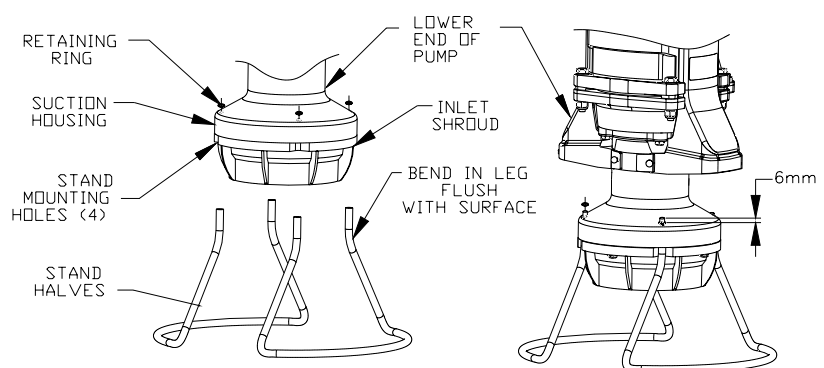

**Fig. 8 - Pump Stand Installation**

O-ring and back-up ring should slide into the bore of the check valve housing. The hose should be oriented as shown in Figure 9 to support alignment with the station discharge valve.

4. Secure the hose assembly to the pump by tightening the slip nut onto the check valve housing. Overtightening the slip nut may damage the check valve. The slip nut should only be tightened to  $\frac{1}{4}$  to  $\frac{1}{2}$  turn beyond hand-tight.
5. Using the pump lifting harness, lower the grinder pump into the tank until the pump stand rests on the bottom surface of the tank. Orient the pump in the basin so that the curved end of the discharge hose is aligned with the discharge valve receiver.
6. Slide the curved, stainless steel end of the discharge hose assembly into the discharge valve receiver until the raised bead contacts the top of the valve receiver. Both the O-ring and back-up ring should slide into the bore of the valve receiver.
7. Secure the hose assembly to the discharge valve by tightening the slip nut onto the valve receiver. The slip nut should only be tightened to  $\frac{1}{4}$  to  $\frac{1}{2}$  turn beyond hand-tight.
8. The valve handle should be left in the "OFF" (horizontal) position until system start-up testing is conducted.

After completing the plumbing, proceed with connecting the pump power cable. The grinder pump power cable is supplied with the mating half of the EQD connector. Verify that the EQD O-rings are in place on the grinder pump power cord (Figure 7). Plug the pump power cable into the supply cable EQD connector. Note that the EQD halves are "keyed" and the plug connections can only be made one way. Secure the EQD connection by tightening the locking ring until it stops. Using the provided hanging

hooks, secure the EQD and supply cable at the top of the tank (Figure 7).

#### 14. Start-Up Procedure

When the system is completely installed, the station should be checked to ensure proper installation and reliable performance.

#### SYSTEM INSPECTION

Perform the following inspections:

- Proper burial depth – the tank should have been buried to the burial level shown (Figure 4).
- Proper grading – the surrounding soil should be graded down, away from the station.
- Station supply cable – the station supply cable must not be exposed outside of the station. Suitable conduit, per AS3000, should be used. Proper burial depth (500 mm)

shall be maintained.

- Alarm panel – ensure that the alarm panel is properly mounted and free of any damage. Verify that the alarm panel has been wired properly in accordance with the wiring instructions provided with the panel.

#### ELECTRICAL TESTS

The following electrical tests are recommended prior to operating the grinder pump station. These tests require the use of appropriate electrical test equipment and should only be performed by qualified personnel trained in the safe operation of this equipment and electrical system servicing.

1. Ensure that the electrical power supplying the control panel is "OFF".
2. Ensure that the grinder pump and alarm circuit breakers in the alarm panel are in the "OFF" position.

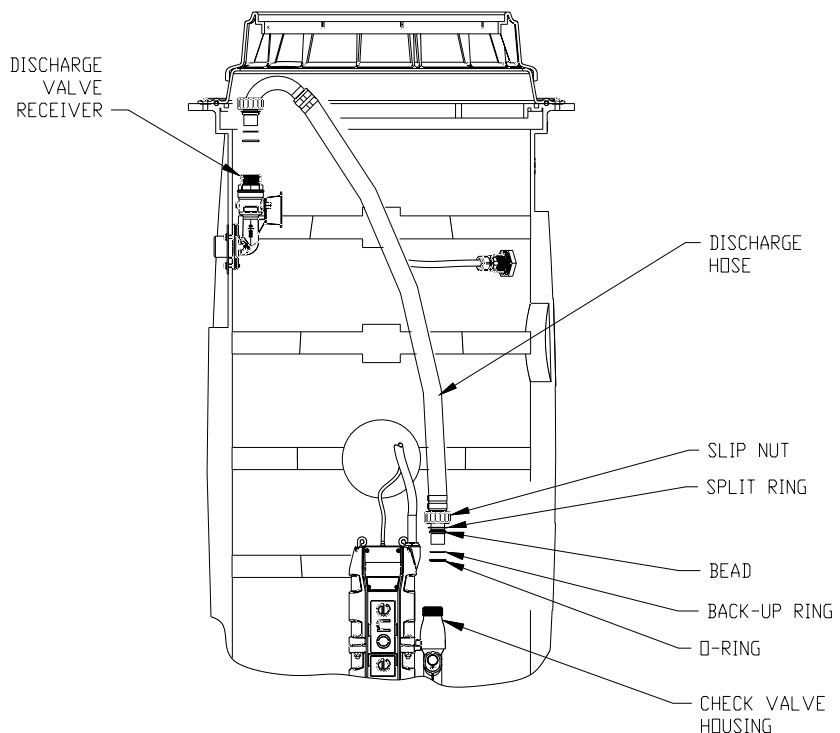

**Fig. 9 - Grinder Pump Installation**

3. Perform Continuity Test procedure in accordance with the Environment One 2000i Grinder Pump Service Manual.
4. Turn "ON" the power to the alarm panel from the building service panel.
5. Using a test (volt) meter, verify that the incoming panel voltage is within 10% of the pump nameplate voltage (for 240V pump, voltage at panel must be 216V to 264V). **If the voltage is outside of this range, do not continue with station start-up. The voltage problem must be corrected prior to proceeding.**

### START-UP TEST

The following test must be performed prior to placing the system in service:

1. Ensure all service and alarm panel breakers are in the "OFF" position.
2. Open the discharge valve in the tank by swinging the valve handle to the "ON" (vertical) position.
3. Open any additional discharge lines. Some installations may have additional discharge line valves before entering the street main.
4. Turn "ON" power to the alarm panel, from the building service panel.
5. Set the alarm circuit breaker in the alarm panel to the "ON" position.
6. Fill the polyethylene tank with water until the red alarm light on the alarm panel is lit and the alarm buzzer sounds. Shut off the fill water.
7. Set the grinder pump circuit breaker in the alarm panel to the "ON" position. Once power is turned on to the grinder pump:
  - The grinder pump should start immediately.
  - The red alarm lamp and buzzer should switch off in approximately 3 minutes.

- The pump should stop within approximately an additional 2 minutes.

### OPERATIONAL ELECTRICAL TEST

The following electrical test is recommended in conjunction with the Start-Up Test of the grinder pump station. This test requires the use of appropriate electrical test equipment and should only be performed by qualified personnel trained in the safe operation of this equipment and electrical system servicing.

1. The current to the grinder pump should be measured in the alarm panel, at the black wire supplying the pump station (supply cable).
2. Using an ammeter, measure the current in the black wire while the pump is operating.
3. The current should be between 5 amps and 6.7 amps.
4. Higher amperage indicates higher discharge pressure. Measured current in excess of 6.7 amps could indicate a blocked or closed discharge line. Correct any blockage problems and confirm that the current is within the acceptable range. **If the current remains outside of the acceptable range, and no discharge blockage is detected, contact your local Environment One or qualified service representative.**

# Lifting Instructions

**FAILURE TO FOLLOW THESE INSTRUCTIONS COMPLETELY WILL VOID WARRANTY.**

## 1. Transporting unit to installation site:

If the station has been shipped secured to a pallet, lift the unit from the bottom during transportation. Alternatively, lift the unit using 2 nylon straps wrapped around the tank exterior, just below the cover flange as shown below. **Never roll a station or move it on its side.**

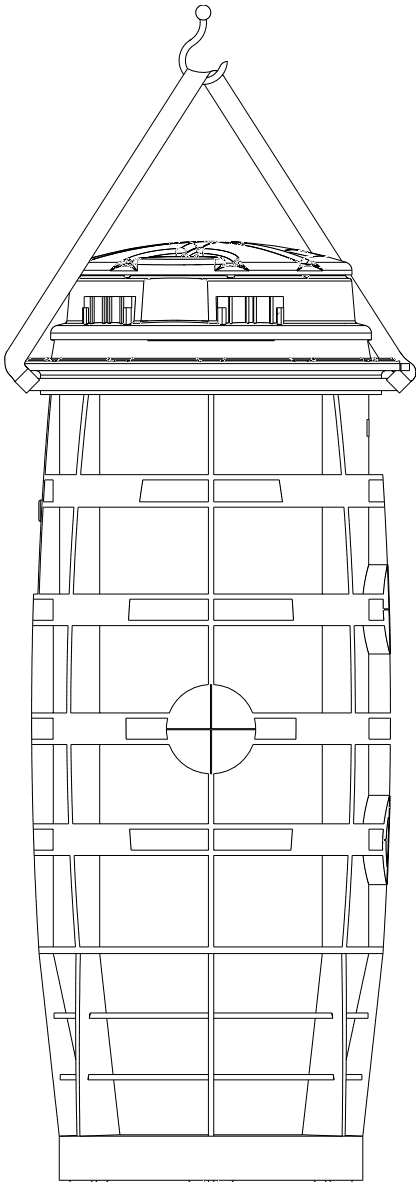

## 2. No Ballast, (to be poured in place):

If the concrete anchor is to be poured while the station is in place lift the unit using 2 nylon straps wrapped around the tank exterior just below the cover flange, as shown below. Keep station oriented vertically to avoid any damage.

## 3. Precast Ballast:

Never lift a station that has ballast attached by any means except the lifting hooks. The weight of the concrete will damage the station if you attempt to lift it from any part of the station.

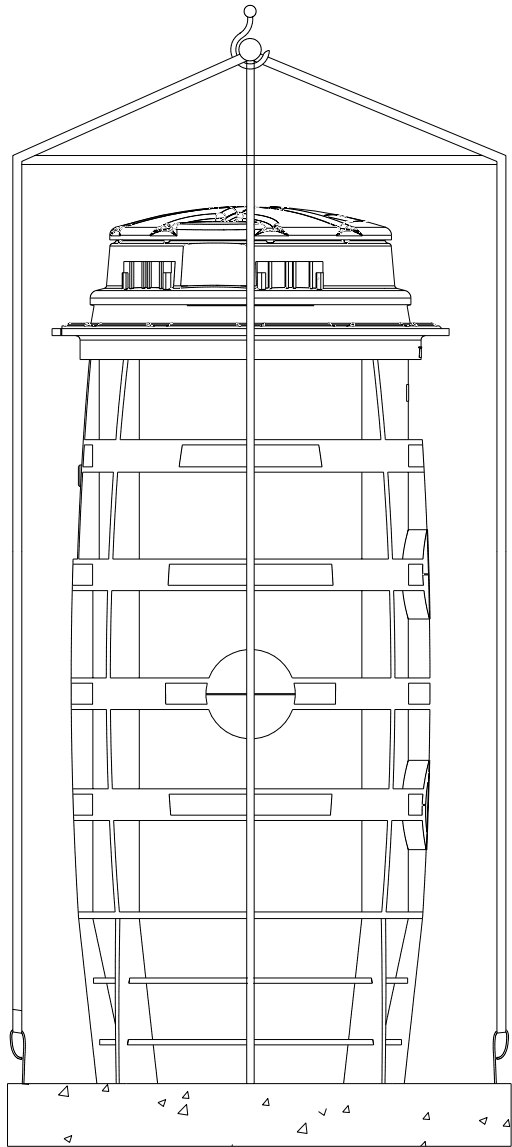

# **E/One Series 2010iP Grinder Pump Station**

## **Ballast Calculations**

A ballast, or concrete anchor, of proper volume and weight is required on most in-ground installations. The following section explains how to arrive at the correct size ballast. The amount of ballast needed is equal to the weight it would take to counterbalance the buoyant force exerted on a fully submerged station.

### **Installation Site Assumptions**

1. Water table – under worst case, the ground water level is assumed to be at the finished grade level.
2. Backfill materials per E/One Installation Instructions (Model 2010iP).
3. The consulting engineer should perform a soil test to determine if the assumptions that have been made are valid for the specific installation site. If the site conditions differ from these assumptions, then the consulting engineer may revise the calculations as shown in this document.

### **Physical Constants**

1. Density of Water =  $1000 \text{ kg/m}^3$
2. Density of Concrete (in air) =  $2402 \text{ kg/m}^3$
3. Density of Concrete (in water) =  $1402 \text{ kg/m}^3$
4. Density of Saturated Backfill =  $1120 \text{ kg/m}^3$

### **Procedure**

#### **A. Determine The Buoyant Force Exerted On The Station**

1. Determine the buoyant force that acts on the grinder pump station when it is submerged in water.
2. Subtract the weight of the tank from the buoyant force due to the submerged tank to determine the net buoyant force acting on the station.

#### **B. Determine The Ballast Force Exerted On The Station**

1. Determine the ballast force applied to the station from the concrete and saturated soil surrounding the station.

#### **C. Subtract The Ballast Force From the Buoyant Force.**

1. Note – if the installation site conditions are different from those listed above, the consulting engineer should recalculate the concrete ballast.

### **Ballast Calculations**

The following calculations are to outline the areas used to determine the volumes of the different materials for the ballast. All sections referred to in the calculations are marked on the accompanying drawing.

# E/One Series 2010iP Grinder Pump Station Ballast Calculations

## Sample Calculation GP 2010iP, 800mm x 2100mm Station

Volume of Station = .79 m<sup>3</sup>

Tank Weight = 75 kg

Station Height = 2.02 m

### A. Buoyant Force

1. The buoyant force acting on the submerged GP 2010iP is equal to the weight of the displaced water for the section of the tank that is submerged.

$$\begin{aligned}F_{\text{buoyant}} &= (\text{density of water})(\text{volume of station}) \\ &= (1000 \text{ kg/m}^3)(.79 \text{ m}^3) \\ &= 790 \text{ kg}\end{aligned}$$

2. The net buoyant force acting on the station ( $F_{\text{net-buoyant}}$ ) is equal to the buoyant force ( $F_{\text{buoyant}}$ ) minus the weight of the station tank.

$$\begin{aligned}F_{\text{net-buoyant}} &= 790 \text{ kg} - 75 \text{ kg} \\ &= 715 \text{ kg}\end{aligned}$$

### B. Ballast Force

1. Determine the volume of concrete & soil

#### Section I: Used To Determine The Volume Of Concrete

(Note: .691m = assumed, inside diameter of concrete ballast ring around tank bottom flange)

$$\begin{aligned}\text{Volume} &= (\text{Height})(\text{Area}) \\ &= (.178 \text{ m})(\pi)((1.066 \text{ m})^2 - (.691 \text{ m})^2)/4 \\ &= (.178 \text{ m})(.517 \text{ m}^2) \\ &= .092 \text{ m}^3\end{aligned}$$

#### Section II: Used To Determine The Volume Of Saturated Soil

(Note: .815 m = assumed, inside diameter of soil column around tank maximum diameter)

$$\begin{aligned}\text{Volume} &= (\text{Height})(\text{Area}) \\ &= (2.02 \text{ m} - .178 \text{ m})(\pi)((1.066 \text{ m})^2 - (.815 \text{ m})^2)/4 \\ &= (1.842 \text{ m})(.371 \text{ m}^2) \\ &= .683 \text{ m}^3\end{aligned}$$

2. Determine the combined ballast

$$\begin{aligned}\text{Ballast (total)} &= \text{Ballast (concrete)} + \text{Ballast (saturated soil)} \\ &= (V_{\text{concrete}})(\text{density concrete in water}) + (V_{\text{soil}})(\text{density saturated soil}) \\ &= (.092 \text{ m}^3)(1402 \text{ kg/m}^3) + (.683 \text{ m}^3)(1120 \text{ kg/m}^3) \\ &= 128 \text{ kg} + 765 \text{ kg} \\ &= 892 \text{ kg}\end{aligned}$$

- C. Subtract the net buoyant force from the ballast force to determine the final condition

$$\begin{aligned}\text{Final Condition} &= \text{Ballast Force} - \text{Net Buoyant Force} \\ &= 892 \text{ kg} - 715 \text{ kg} \\ &= 177 \text{ kg (excess ballast)}\end{aligned}$$



# E/One Series 2010iP Grinder Pump Station Ballast Calculations

## Sample Calculation GP 2010iP, 800mm x 2100mm Station Continued

The approach outlined on previous page may be used to calculate the ballast requirements listed below.

Chart 1

GP Model 2010iP	Station Volume (m <sup>3</sup> )	FNet Bouyant (kg)	Tank Weight (kg)	FBallast (kg)	Volume Concrete (m <sup>3</sup> )*	Weight Concrete in Air (kg)*	Minimum Diameter of Concrete Anchor (mm)	Minimum Thickness of Concrete Anchor (mm)
800 x 1900	.72	646	74	892	0.09	216	1,066	178
800 x 2000	.72	646	74	892	0.09	216	1,066	178
800 x 2100	.79	715	75	892	0.09	216	1,066	178

\* Volume calculated is for minimum dimensions given. Minimum dimensions must be met or exceeded for actual application.

# MODEL 2010iP

## 800MM X 2100MM

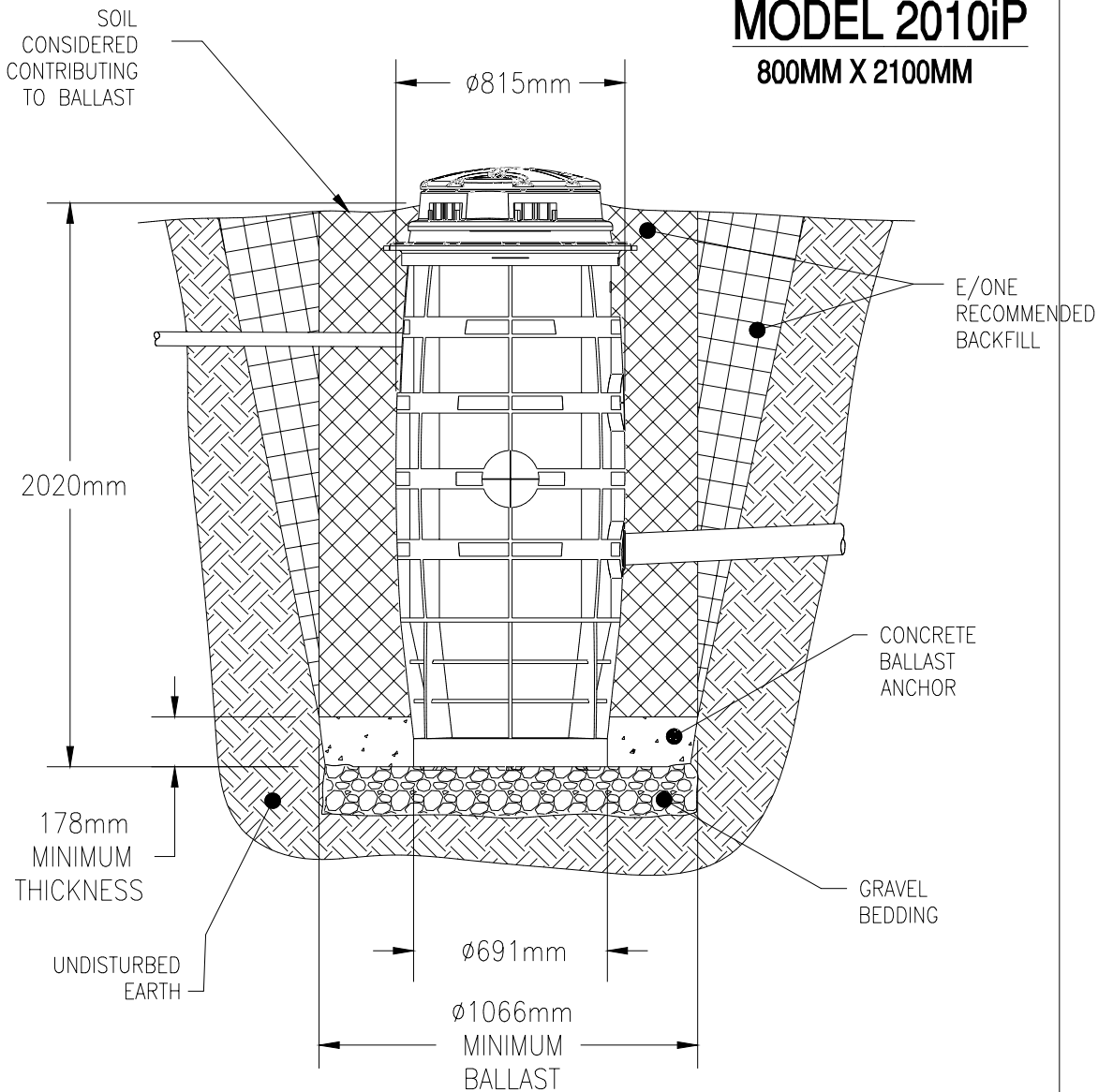

PD	SZ	4/24/06	-	N/A
DR BY	CHK'D	DATE	ISSUE	SCALE
 SEWER SYSTEMS				
MODEL 2010iP BALLAST INFORMATION (800mm X 2100mm)				









*A Precision Castparts Company*

---

Environment One Corporation  
2773 Balltown Road  
Niskayuna, New York 12309-1090  
USA  
Voice: (01) 518.346.6161  
Fax: 518.346.6188

[www.eone.com](http://www.eone.com)

PA2105P01 Rev. B  
8/08