

E/One Sentry™

Alarm Panel — Basic Package

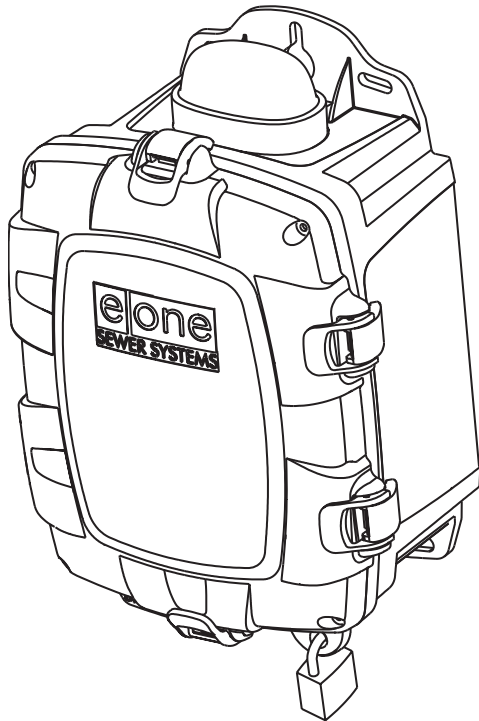

Description

The E/One Sentry panels are custom designed for use with Environment One grinder pump stations. They can be configured to meet the needs of your application, from basic alarm indication to advanced warning of pending service requirements.

E/One Sentry panels are supplied with audible and visual high level alarms. They are easily installed in accordance with relevant national and local codes. Standard panels are approved by UL, CSA, CE and NSF to ensure high quality and safety.

The panel features a corrosion-proof, NEMA 4X-rated, thermoplastic enclosure. A padlock is provided to prevent unauthorized entry (safety front).

Standard Features

- Circuit breakers, 240 or 120 VAC service
- Terminal blocks and ground lugs
- Audible alarm with manual silence
- Manual run feature and run indicator
- Redundant "Start" function with high level alarm
- Conformal-coated alarm board (both sides)
- Alarm board overload protection

Optional Features

- Contact group (dry, powered and Remote Sentry)
- Inner cover (dead front)
- Hour meter
- Generator receptacle with auto transfer
- Main service disconnect

Please consult factory for special applications.

SIMPLEX SENTRY

REDUNDANT RUN (HIGH LEVEL)
 EXTERNAL VISUAL & AUDIBLE ALARM
 EXTERNAL LATCHING MANUAL SILENCE
 MANUAL RUN
 PUMP RUN INDICATOR
 CONFORMAL COATED CIRCUIT BOARD
 PADLOCK
 NEMA 4X ENCLOSURE ASSEMBLY
 CORROSION PROOF THERMOPLASTIC
 POLYESTER APPROVED BY UL FOR
 ELECTRICAL CONTROL ENCLOSURE

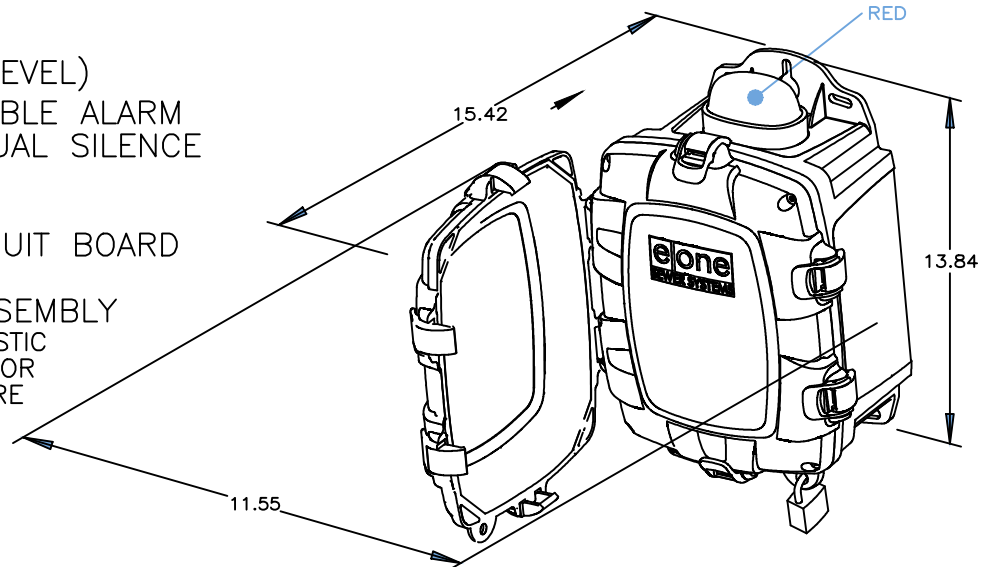

OPTIONS:

ALARM CONTACTS

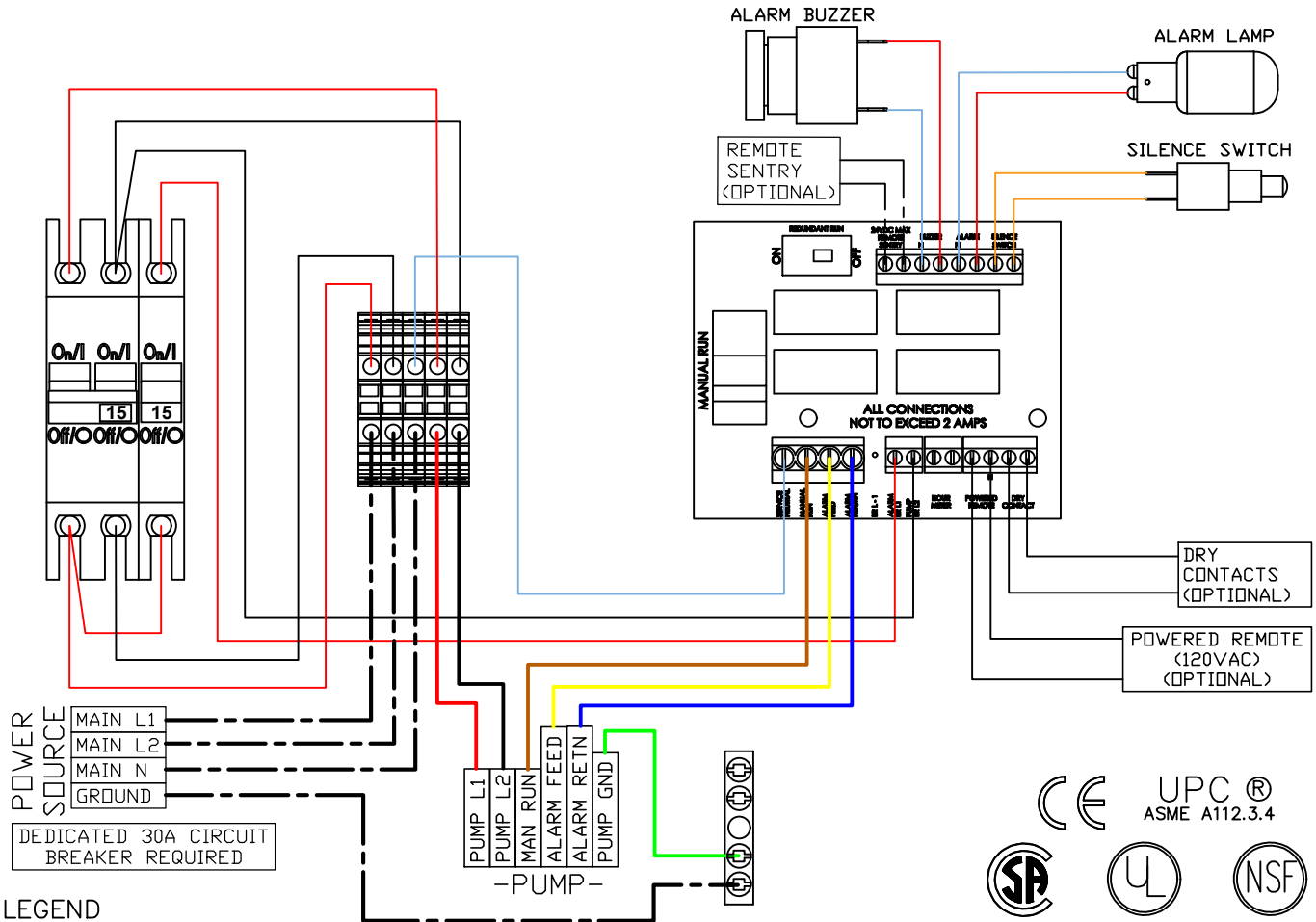

POWER SOURCE
 MAIN L1
 MAIN L2
 MAIN N
 GROUND

DEDICATED 30A CIRCUIT BREAKER REQUIRED

LEGEND

- FROM CORE
- - - SUPPLY CABLE
- FACTORY INSTALLED

PIN	FUNCTION	2000S	EXTREME
1	MANUAL RUN	RED	BROWN
2	L1	BLACK	RED
3	L2	WHITE	BLACK
4	GND	GREEN	GRN/YEL
5	ALARM FEED	ORANGE	YELLOW
6	ALARM RETURN	BLUE	BLUE

CONTROL CABLE:
 TYPE TC: DIRECT BURIAL, 12AWG,
 SIX CONDUCTOR

DRWN	MJM
DATE	1/17/2025
CHCK	DRK
ISSUE	—
DATE	1/23/2025

SEWER SYSTEMS
 SIMPLEX SENTRY, 240V 60Hz.
 DOUBLE POLE POWER
 LM000326 P1

SIMPLEX SENTRY

REDUNDANT RUN (HIGH LEVEL)
 EXTERNAL VISUAL & AUDIBLE ALARM
 EXTERNAL LATCHING MANUAL SILENCE
 MANUAL RUN
 PUMP RUN INDICATOR
 CONFORMAL COATED CIRCUIT BOARD
 PADLOCK
 NEMA 4X ENCLOSURE ASSEMBLY
 CORROSION PROOF THERMOPLASTIC
 POLYESTER APPROVED BY UL FOR
 ELECTRICAL CONTROL ENCLOSURE

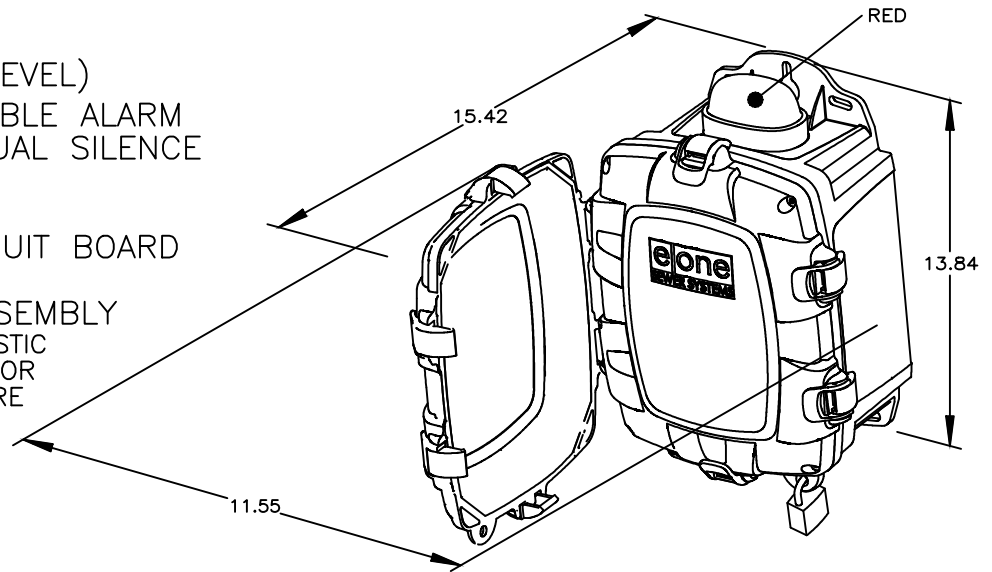

OPTIONS:

- ALARM CONTACTS
- HOUR METER

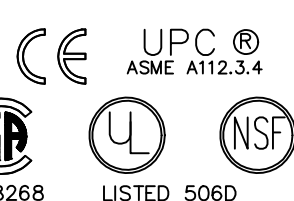
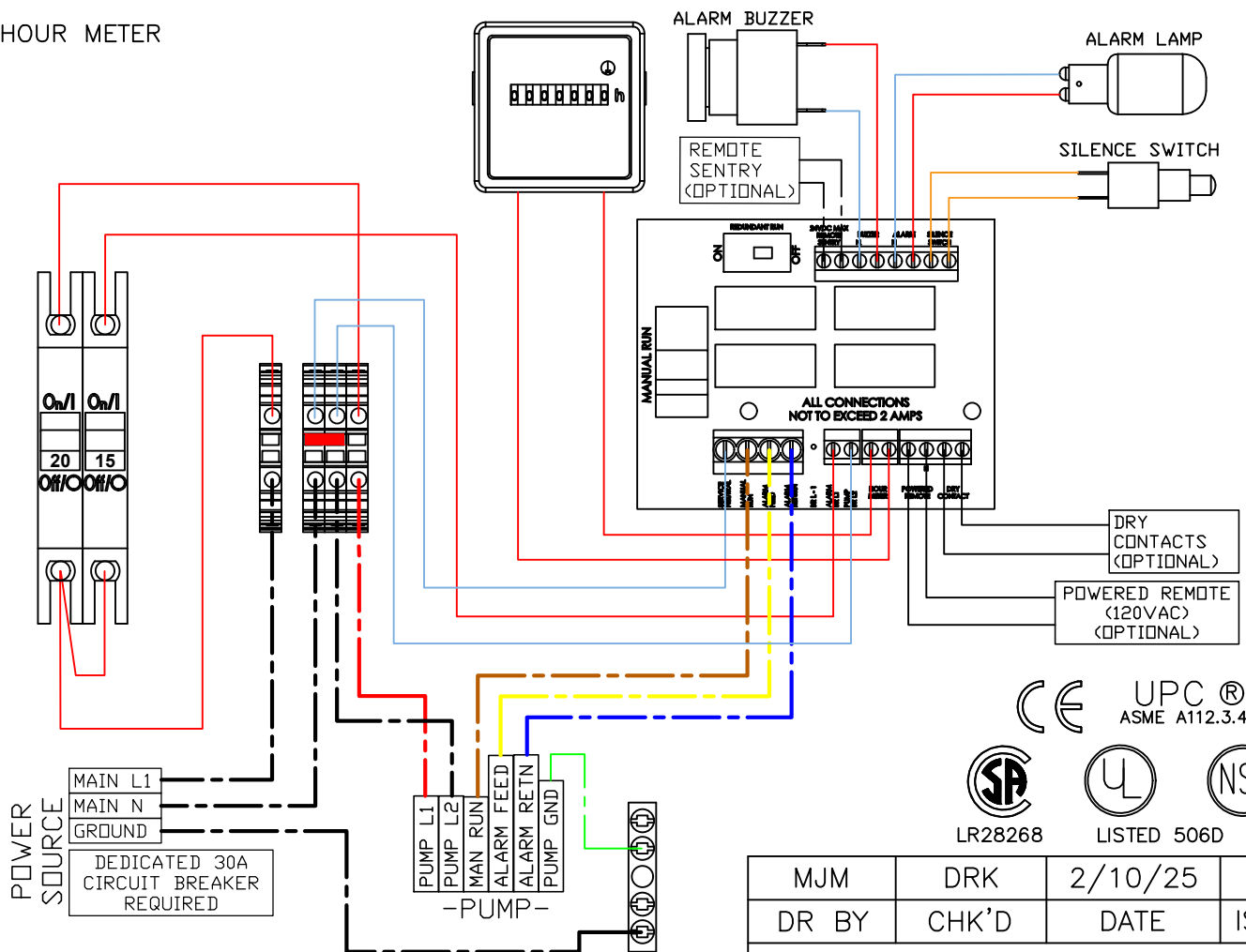

LR28268 LISTED 506D

PIN	FUNCTION	2000S	EXTREME
1	MANUAL RUN	RED	BROWN
2	L1	BLACK	RED
3	L2	WHITE	BLACK
4	GND	GREEN	GRN/YEL
5	ALARM FEED	ORANGE	YELLOW
6	ALARM RETURN	BLUE	BLUE

CONTROL CABLE:
 TYPE TC: DIRECT BURIAL, 12AWG,
 SIX CONDUCTOR

MJM	DRK	2/10/25	E
DR BY	CHK'D	DATE	ISSUE



SIMPLEX SENTRY, 120V 60Hz.
 SINGLE POLE POWER

LM000327