

WH101

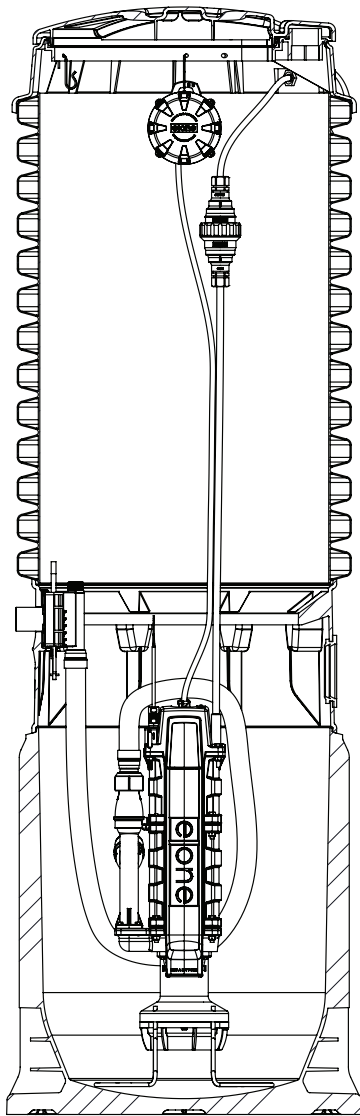

General Features

The model WH101 grinder pump station is a complete unit that includes: the grinder pump, check valve, HDPE (high density polyethylene) tank, controls, and alarm panel. A single WH101 can accommodate the sewage flow from two, average single-family homes.

- Rated for flows of 700 gpd (2650 lpd)
- 100 gallons (379 liters) of capacity
- Standard outdoor heights range from 60 inches to 159 inches

The WH101 has a cable that connects the motor controls to the level controls through watertight penetrations.

Operational Information

Motor

1 hp, 1,725 rpm, high torque, capacitor start, thermally protected, 120/240V, 60 Hz, 1 phase

Inlet Connections

4-inch inlet grommet standard for DWV pipe. Other inlet configurations available from the factory.

Discharge Connections

Pump discharge terminates in 1.25-inch NPT female thread or socket fitting. Can easily be adapted to 1.25-inch PVC pipe or any other material required by local codes.

Discharge

15 gpm at 0 psig (0.95 lps at 0 m)
11 gpm at 40 psig (0.69 lps at 28 m)
7.8 gpm at 80 psig (0.49 lps at 56 m)

Accessories

E/One requires that the Uni-Lateral, E/One's own stainless steel check valve, be installed between the grinder pump station and the street main for added protection against backflow.

Alarm panels are available with a variety of options, from basic monitoring to advanced notice of service requirements.

The Remote Sentry is ideal for installations where the alarm panel may be hidden from view.

WH101-124

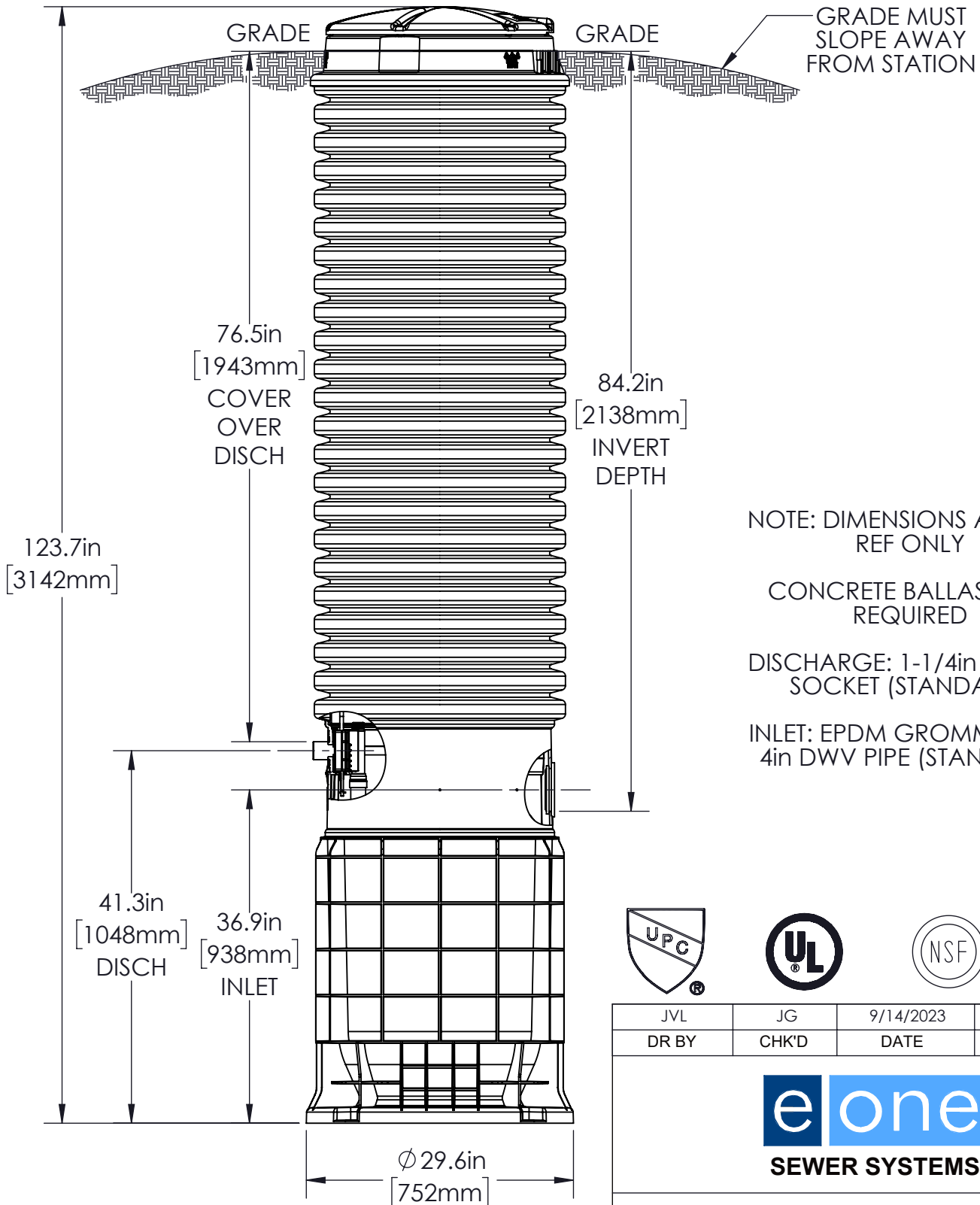

JVL	JG	9/14/2023	F	1:16
DR BY	CHK'D	DATE	ISSUE	SCALE



SEWER SYSTEMS

**MODEL WH101-124
CUT SHEET**

NA0057P06

WH101-159

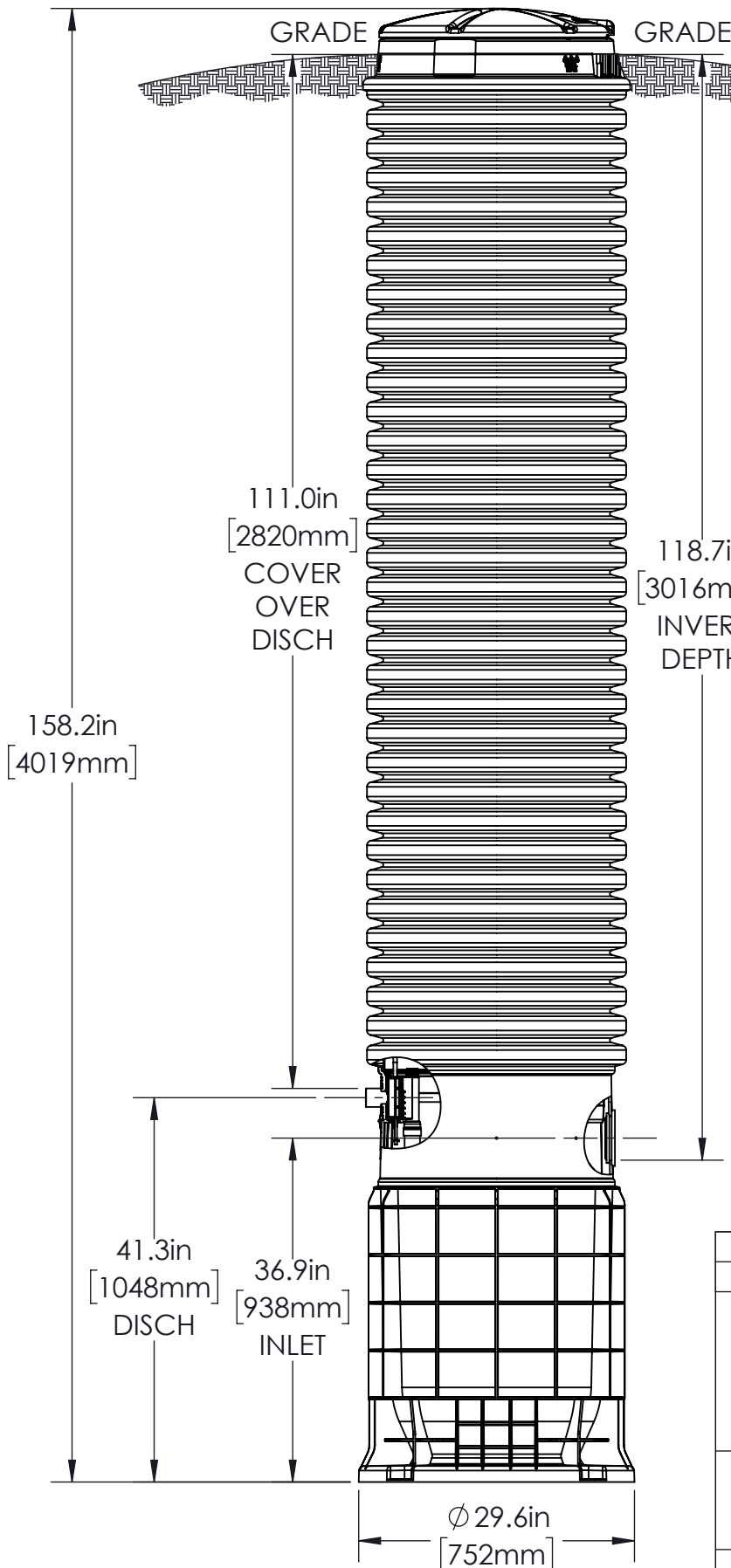

GRADE MUST SLOPE AWAY FROM STATION

NOTE: DIMENSIONS ARE FOR REF ONLY

CONCRETE BALLAST NOT REQUIRED

DISCHARGE: 1-1/4in FEMALE SOCKET (STANDARD)

INLET: EPDM GROMMET FOR 4in DWV PIPE (STANDARD)



JVL	JG	9/14/2023	F	1:18
DR BY	CHK'D	DATE	ISSUE	SCALE



SEWER SYSTEMS

**MODEL WH101-159
CUT SHEET**

NA0057P07