

# E/One T260

**Duplex Alternating Alarm Panel — For Explosionproof Pumps**

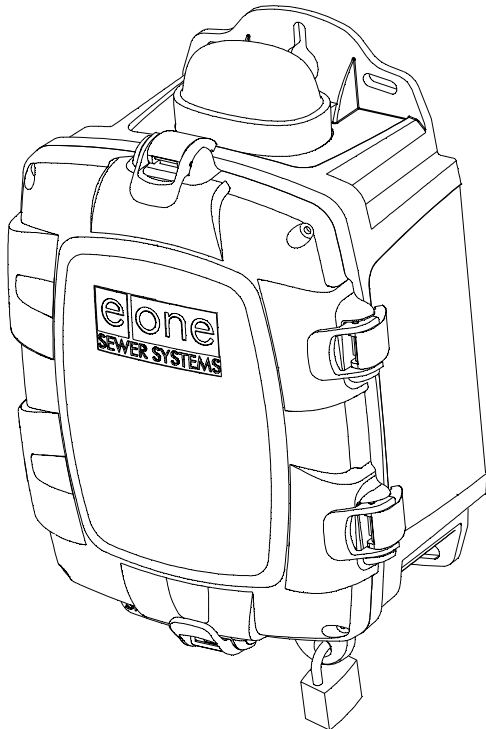

## Description

The T260 Duplex Alternating Alarm panel is custom designed for use with Environment One explosionproof grinder pumps in duplex stations.

Duplex grinder pump stations, a station with two grinder pumps, require the pumping load to be shared equally between the two pumps. Under normal conditions, one pump removes the accumulated sewage from the grinder pump basin. After 24 hours, the T260 Alternating Panel toggles the electrical supply power to the pump that was idle. If the sewage level reaches the alarm level, the two grinder pumps will operate simultaneously for 3 to 4 minutes. If, after that time, the sewage is not below the alarm level, the alarm circuit is engaged.

The T260 Alternating Panel is supplied with audible and visual high water level alarms and indication of internal moisture intrusion to the pump. The panel is easily installed in accordance with relevant national and local codes.

The T260 Panel is listed by UL, CSA, CE and NSF to ensure high quality and safety.

The panel features a corrosionproof, NEMA 4X-rated, UL-approved thermoplastic enclosure with padlock to prevent unauthorized entry (safety front).

## Standard Features

Includes circuit breakers for 240 VAC service, terminal blocks and ground lugs, audible alarm with manual silence, manual run feature with Run indicator and redundant Start function with high level alarm.

Dry contacts

Lead/lag, run and alarm indicator lights

Pump internal moisture detection indicator

## Optional Features

Hour meters (with larger enclosure)

E/One Remote Sentry ready (with power loss capability)

Dead front (inner door)

Generator receptacle with auto transfer

GFCI receptacle

Auto dialer

\*\* Consult factory for special applications

# DUPLEX T260 ALTERNATING PANEL USED WITH WX SERIES PUMP

EXTERNAL VISUAL & AUDIBLE ALARM  
EXTERNAL LATCHING MANUAL SILENCE  
CORE(PUMP) LEAK DETECTION ALARM  
MANUAL RUN  
PUMP RUN INDICATORS  
CONFORMAL COATED CIRCUIT BOARD  
PADLOCK  
ALARM DRY CONTACT  
NEMA 4X ENCLOSURE ASSEMBLY

CORROSION PROOF THERMOPLASTIC  
POLYESTER APPROVED BY UL FOR  
ELECTRICAL CONTROL ENCLOSURE

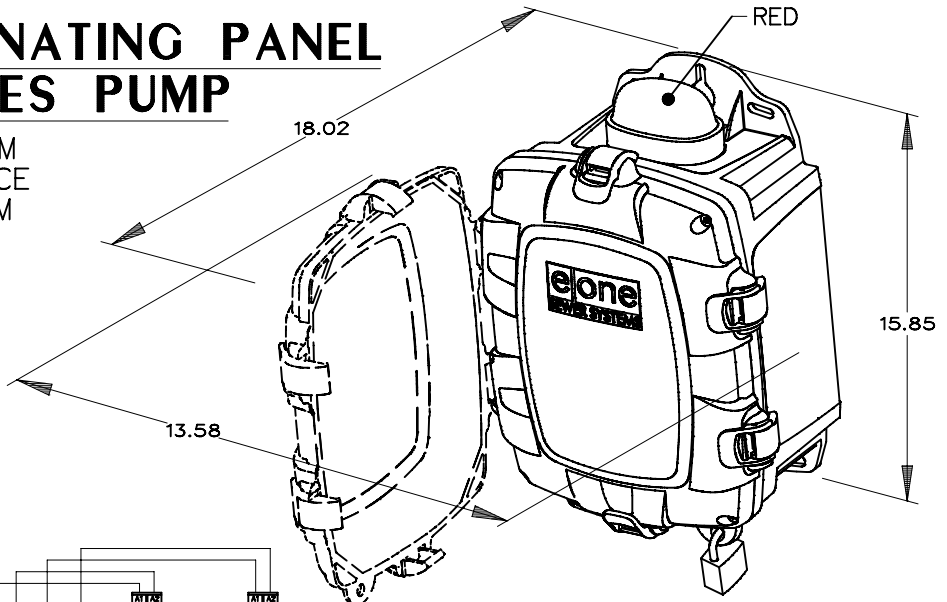

## OPTIONS:

HOUR  
METER

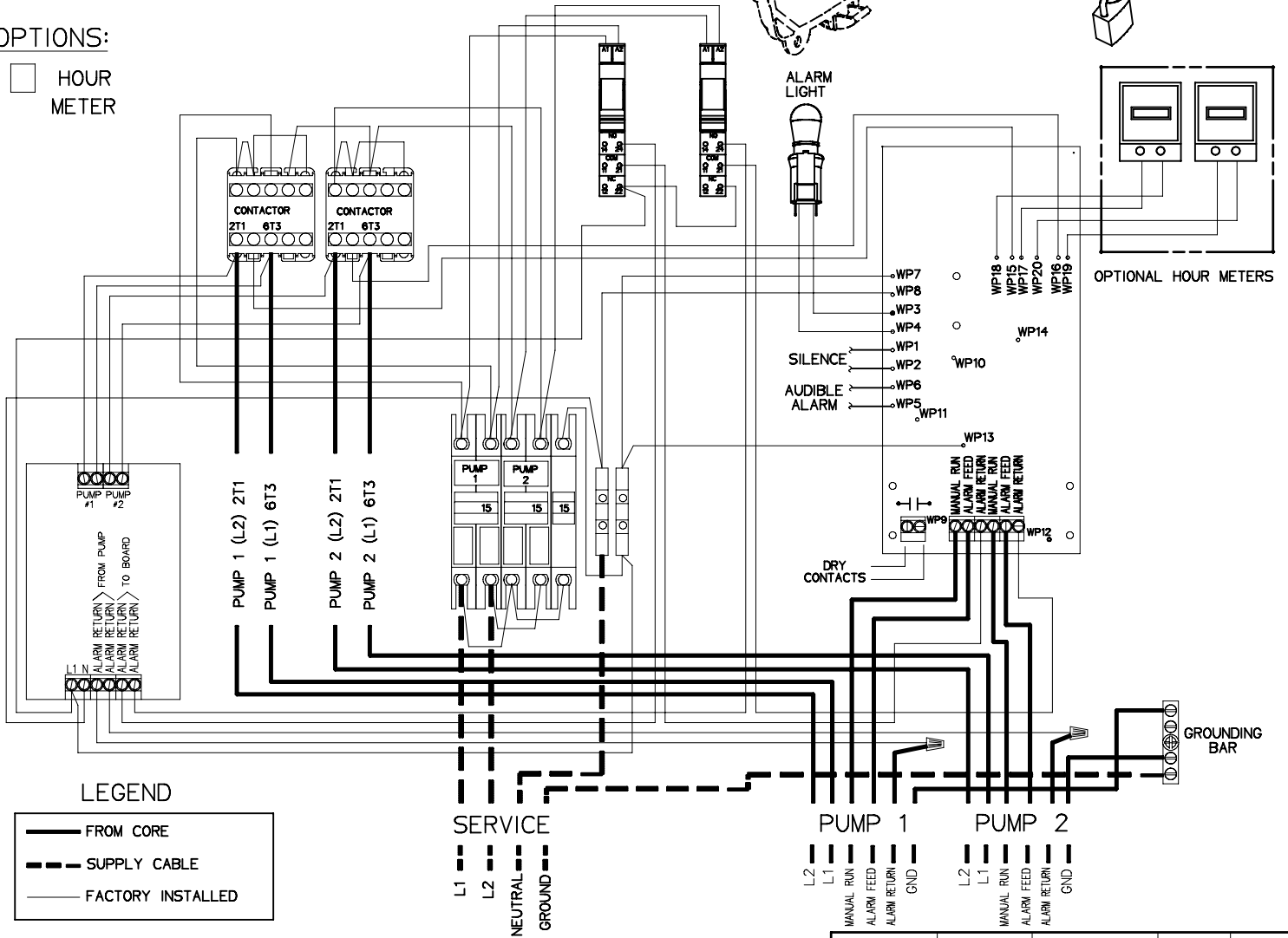

## LEGEND

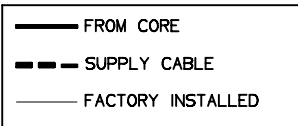

## WX EXTREME WIRE COLOR MAP

PIN	FUNCTION	COLOR
1	MANUAL RUN	RED
2	L1	BLACK
3	L2	WHITE
4	GND	GREEN
5	ALARM FEED	ORANGE
6	ALARM RETURN	BLUE

CONTROL CABLE:  
TYPE TC: DIRECT BURIAL, 12AWG,  
SIX CONDUCTOR

CE UPC®  
ASME A112.3.4



CT	SGS	04/03/08	-	N/A
DR BY	CHK'D	DATE	ISSUE	SCALE



DUPLEX T-260 ALTERNATING PANEL  
FOR USE WITH WX SERIES PUMP  
240V 60Hz DOUBLE POLE POWER

LM000381